



Microelectronic gauge pressure sensors MP Series

- ▶ Resolution 0,01 %
- ▶ Operating pressure range
from 0-1 to 0-150 MPa
- ▶ Operating temperature range
from -45 to +200 °C
- ▶ Electrical insulation
strength – 500 V
- ▶ Titanium body

Applications

- Oil and gas industry
- Hydraulics/Pneumatic
- Pumping stations/ Compressors

- The sensors are intended for proportional conversion of pressure into electric signal.

New solutions in pressure measurement – “Silicon-on-Sapphire” Technology

✓ Sensitive element of pressure sensors is a two-layer sapphire-titanium diaphragm with monocrystal silicon resistance strain gauges.

✓ Monocrystal sapphire diaphragm is a perfect elastic element that due to connection with titanium acquires the best quality as to the deformation level, and preserves its elastic properties up to +400°C.

✓ Monocrystal silicon resistance strain gauges are automatically connected with sapphire (heteroepitaxy method) and provide almost no hysteresis or fatigue effects.

✓ Exceptional insulating properties and radiation resistance of sapphire enable to use the sensitive element within temperature range from -200 to +350°C under the effect of high electromagnetic interferences and radiation.

✓ Strain gauges elements are manufactured in groups by solid-state micro-electronic methods and provide high quality and good repeatability of the output parameters.



Microtensor

Pressure sensors MP Series

Datasheet

1 Nominal, overload and burst pressure

Designation	Nominal pressure, MPa	Overload pressure, MPa	Burst pressure, MPa
MP 1...	0...1	-0,1...2	3
MP 1,6...	0...1,6	-0,1...3,2	4,8
MP 2,5...	0...2,5	-0,1...5	7,5
MP 4...	0...4	-0,1...8	12
MP 6...	0...6	-0,1...12	18
MP 10...	0...10	-0,1...20	30
MP 16...	0...16	-0,1...32	48
MP 25...	0...25	-0,1...50	75
MP 40...	0...40	-0,1...80	120
MP 60...	0...60	-0,1...120	180
MP 100...	0...100	-0,1...150	250
MP 150...	0...150	-0,1...165	300

2 Temperature ranges

2.1 Operating temperature range

2.1.1 Version 1from - 45 to + 125°C

2.1.2 Version 2from - 45 to + 155°C

2.1.3 Version 3from - 45 to + 200°C

Microtensor

Pressure sensors MP Series

2.2 Limiting temperature range

2.2.1 Version 1	from - 60 to + 130°C
2.2.2 Version 2	from - 60 to + 160°C
2.2.3 Version 3	from - 60 to + 205°C

3 Accuracy parameters

3.1 Resolution, % FS	0,01
3.2 Non-linearity, % FS	±0,15
3.3 Hysteresis, % FS	0,05
3.4 Output signal repeatability, % FS	±0,05
3.5 Long-term stability of the output signal range within 12 months, %	±0,15
3.6 Output signal error caused by the influence of overload pressure, % FS	
for zero output signal	±0,2
for output signal range	±0,05
3.7 Additional ambient temperature error, % FS/1°C	
3.7.1 For zero output signal	±0,05
3.7.2 For output signal range	
operating temperature range from -45 to +125 °C	±0,05
operating temperature range from +125 to +200 °C	-0,05±0,025
3.8 Additional vibration error of the output signal, % FS	±0,05

4 Electrical characteristics

4.1 Output signal at room temperature, mV	
4.1.1 Zero output signal	±15
4.1.2 Output signal range (FS)	150±50
for MP 1...	100±35
4.2 Strain gauge bridge resistance at room temperature, kOhm	3,40-4,85
4.3 Temperature resistance coefficient of the strain gauge bridge, K ⁻¹	(1,70±0,15)·10 ⁻³
4.4 Insulation resistance, MOhm	
at room temperature	100
at the upper ambient temperature value	20
4.5 Electrical insulation strength (AC voltage), V	500
4.6 Power supply - stabilized DC voltage, V	1-10
Output signal is rated by the voltage 10 V.	

5 Mechanical characteristics

5.1 Vibration resistance (sinusoidal vibration):	
Frequency range, Hz	from 10 to 5000
Acceleration amplitude, m/s ²	500

Microtensor

Pressure sensors MP Series

5.2 Shock resistance (multiple mechanical shocks):	
Shock acceleration peak, m/s ²	1000
Shock pulse width, ms	2-5
5.3 Torque effect while installation should not be higher, N·m	
for pressure port types M1, U1, U2	25
M2, U3, M3, U4, M4,	
U5, M5, U6, M6, U7	5

6 Operating conditions

6.1 IP level	IP40
6.2 Sensor body (pressure connection part) and membrane are made of titanium alloy with 87 % of titanium.	
6.3 Pressure media - gases, liquids and their mixtures not aggressive to the titanium alloy (air, sea water, 5 % vitriol acid , chlorine water, chloride solutions, oils, ethyne etc).	

Microtensor

Pressure sensors MP Series

7 Overall and mounting dimensions

7.1 Version with pins

MP 1(1,6...150)-...-M1(U1, U2)-P

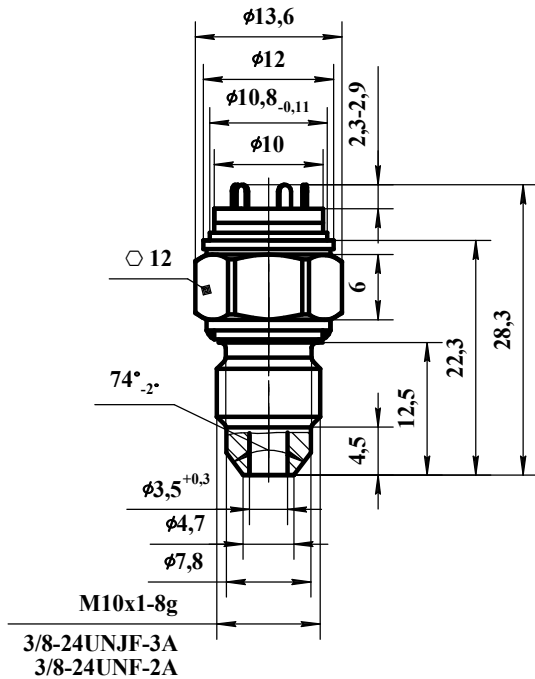

Drawing 1

Thread	Code
M10x1-8g	M1
3/8-24UNJF-3A	U1
3/8-24UNF-2A	U2

7.2 Version with wires

MP 1(1,6...150)-...-M1(U1, U2)-L

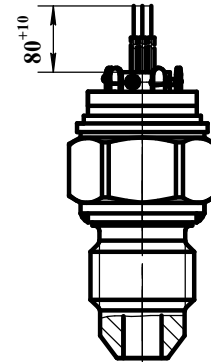

The rest -
ref. drawing 1

Drawing 2

7.3 Thread design

MP 1(1,6...25)-...-M2(U3)-...

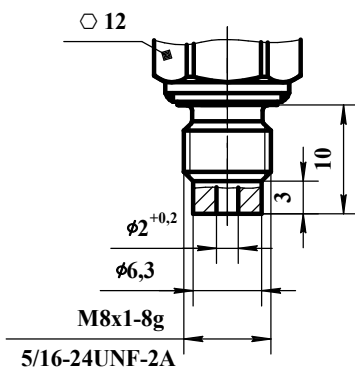

Drawing 3

Thread	Code
M8x1-8g	M2
5/16-24UNF-2A	U3

MP 1(1,6...10)-...-M3(U4)-...

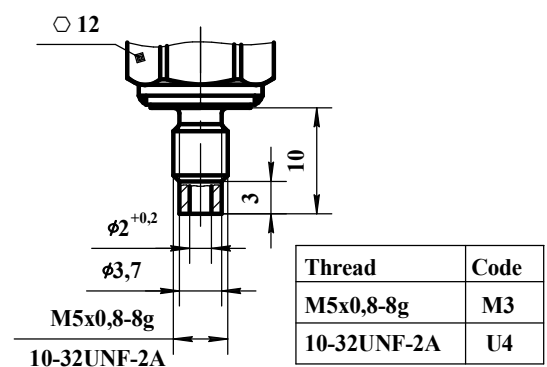

Drawing 4

Thread	Code
M5x0,8-8g	M3
10-32UNF-2A	U4

Microtensor

Pressure sensors MP Series

MP 1(1,6...10)-...-M4(U5)-...

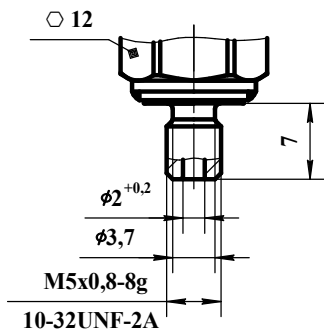

Thread	Code
M5x0,8-8g	M4
10-32UNF-2A	U5

Drawing 5

MP 1(1,6...10)-...-M5(U6)-...

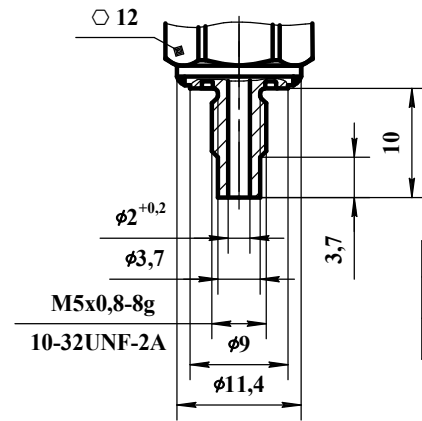

Thread	Code
M5x0,8-8g	M5
10-32UNF-2A	U6

Drawing 6

MP 1(1,6...10)-...-M6(U7)-...

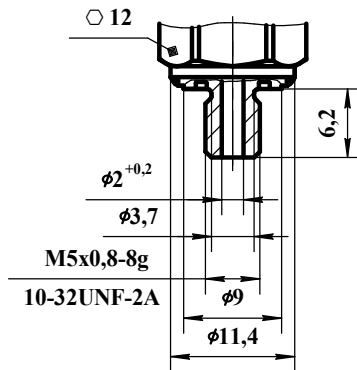

Thread	Code
M5x0,8-8g	M6
10-32UNF-2A	U7

Drawing 7

8 Circuit diagram

Electrical connection - flexible wire with section 0,08 or 0,12 mm² in teflon insulation

"Closed bridge" diagram

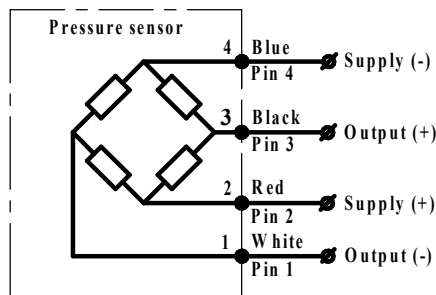

"Open bridge" diagram

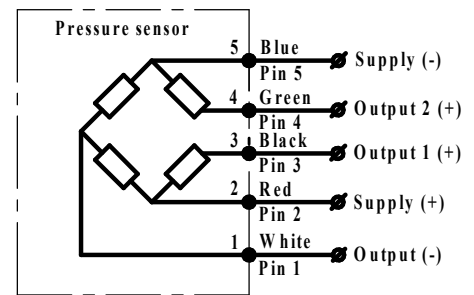

Pins configuration

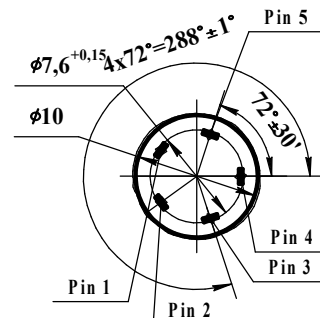
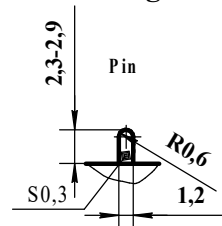
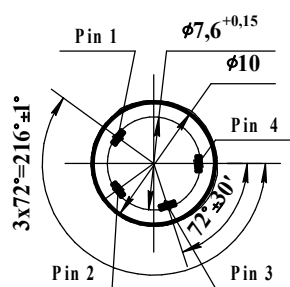

Microtensor

Pressure sensors MP Series

9 Mounting diagrams

MP 1(1,6...150)-...-M1(U1, U2)-...

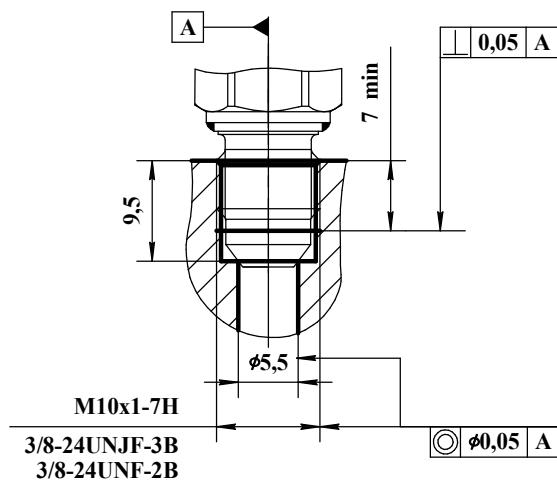

MP 1(1,6...25)-...-M2(U3)-...

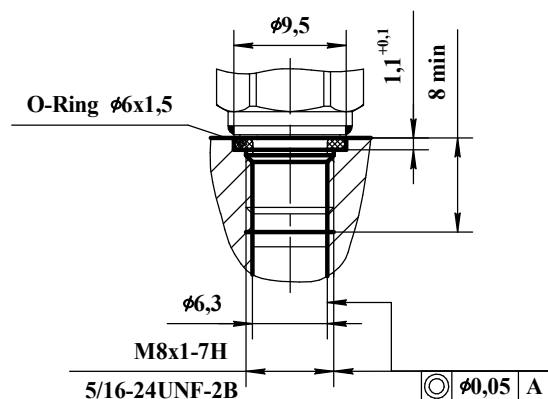

MP 1(1,6...10)-...-M3(U4)-...

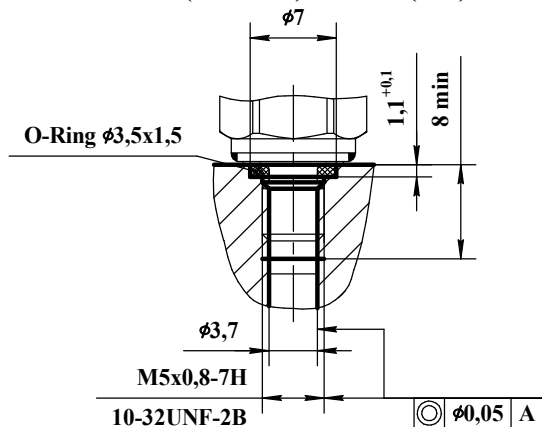

MP 1(1,6...10)-...-M4(U5)-...

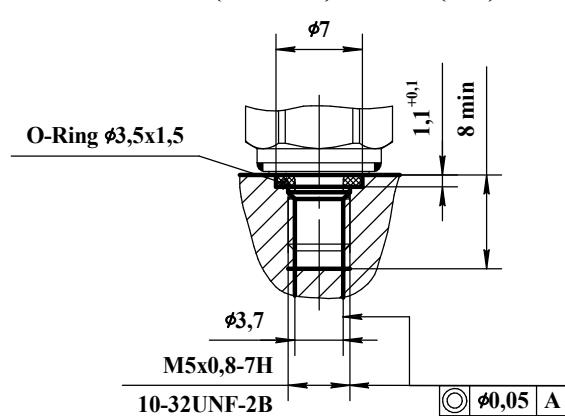

MP 1(1,6...10)-...-M5(U6)-...

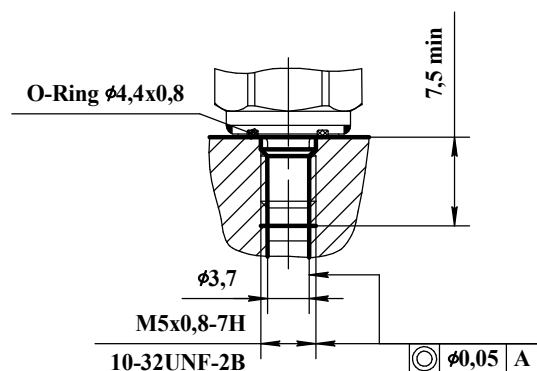

MP 1(1,6...10)-...-M6(U7)-...

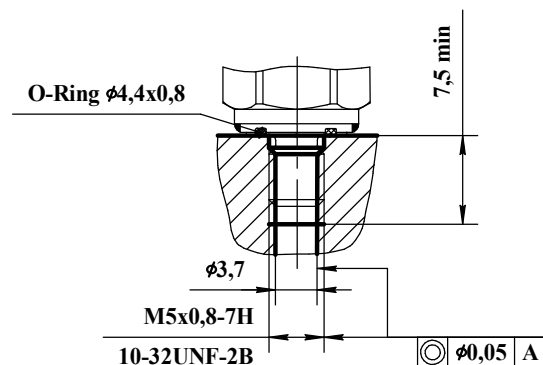

Microtensor

Pressure sensors MP Series

10 Type designation

MP XXX - XX - X - X

Series

Upper gauge pressure limit

1; 1,6; 2,5; 4; 6; 10; 16; 25;
40; 60; 100; 150 MPa

Operating ambient temperature range

Version 1 - from - 45 to + 125 °C;
Version 2 - from - 45 to + 155 °C;
Version 3 - from - 45 to + 200 °C

Circuit

0 - “closed bridge” circuit; 1 - “open bridge” circuit

Thread code

M1 - M10x1-8g (1-150 MPa, drawings 1, 2);
U1 - 3/8-24UNF-3A (1-150 MPa, drawings 1, 2);
U2 - 3/8-24UNF-2A (1-150 MPa, drawings 1, 2);
M2 - M8x1-8g (1-25 MPa, drawing 3);
U3 - 5/16-24UNF-2A (1-25 MPa, drawing 3);
M3, M4, M5, M6 - M5x0,8-8g (1-10 MPa, drawings 4-7);
U4, U5, U6, U7 - 10-32UNF-2A (1-10 MPa, drawings 4-7)

Electrical connection

L - flexible wire 80 mm length; P - pin 2,3-2,9 mm height

Order example of pressure sensor

Pressure sensor of MP series, intended for pressure conversion from 0 to 60 MPa, for operation within temperature range from - 45 to + 200 °C, with “open bridge” circuit, 3/8-24UNF-2A thread and flexible wire 80 mm length:

Pressure sensor MP 60-31-U2-L.

Note: if wished, the wire length (standard 80 mm) can be changed, in this case the required length should be added to the wire code L, for example:

Pressure sensor MP 60-31-U2-L120.

11 Marking

Marking on the sensor body must contain following information: series, upper gauge pressure limit is in MPa, version of the operating temperature range, circuit type, thread code and order number

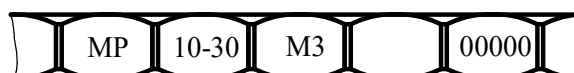

Microtensor

Pressure sensors MP Series