



Microelectronic gauge pressure sensors TM Series

- ▶ Resolution 0,01 %
- ▶ Operating pressure range
from 0-0,1 to 0-100 MPa
- ▶ Operating temperature range
from -45 to +200 °C
- ▶ Electrical insulation
strength – 700 V
- ▶ Titanium body

Applications

- Industrial automatics
- Oil and gas industry
- Hydraulics/Pneumatic
- Pumping stations/ Compressors
- Heat metering

- The sensors are intended for proportional conversion of pressure into electric signal.

New solutions in pressure measurement – “Silicon-on-Sapphire” Technology

∨ Sensitive element of pressure sensors is a two-layer sapphire-titanium diaphragm with monocrystal silicon resistance strain gauges.

∨ Monocrystal sapphire diaphragm is a perfect elastic element that due to connection with titanium acquires the best quality as to the deformation level, and preserves its elastic properties up to +400°C.

∨ Monocrystal silicon resistance strain gauges are automatically connected with sapphire (heteroepitaxy method) and provide almost no hysteresis or fatigue effects.

∨ Exceptional insulating properties and radiation resistance of sapphire enable to use the sensitive element within temperature range from -200 to +350°C under the effect of high electromagnetic interferences and radiation.

∨ Strain gauges elements are manufactured in groups by solid-state micro-electronic methods and provide high quality and good repeatability of the output parameters.



Microtensor

Pressure sensors TM Series

Datasheet

1 Nominal, overload and burst pressure

Designation	Nominal pressure, MPa	Overload pressure, MPa	Burst pressure, MPa
TM 0,1...	0...0,1	-0,1...0,2	0,3
TM 0,16..	0...0,16	-0,1...0,32	0,48
TM 0,25...	0...0,25	-0,1...0,5	0,75
TM 0,4...	0...0,4	-0,1...0,8	1,2
TM 0,6...	0...0,6	-0,1...1,2	1,8
TM 1...	0...1	-0,1...2	3
TM 1,6...	0...1,6	-0,1...3,2	4,8
TM 2,5...	0...2,5	-0,1...5	7,5
TM 4...	0...4	-0,1...8	12
TM 6...	0...6	-0,1...12	18
TM 10...	0...10	-0,1...20	30
TM 16...	0...16	-0,1...32	48
TM 25...	0...25	-0,1...50	75
TM 40...	0...40	-0,1...80	120
TM 60...	0...60	-0,1...120	180
TM 100...	0...100	-0,1...150	250

2 Temperature ranges

2.1 Operating temperature range

2.1.1 Version 1from - 45 to + 125°C

2.1.2 Version 2from - 45 to + 155°C

2.1.3 Version 3from - 45 to + 200°C

Microtensor

Pressure sensors TM Series

2.2 Limiting temperature range

2.2.1 Version 1	from - 60 to + 130°C
2.2.2 Version 2	from - 60 to + 160°C
2.2.3 Version 3	from - 60 to + 205°C

3 Accuracy parameters

3.1 Resolution, % FS	0,01
3.2 Non-linearity, % FS	
3.2.1 For TM 0,1... - TM 1,6...	±0,2
3.2.2 For TM 2,5... - TM 100...	±0,15
3.3 Variation, % FS	0,05
3.4 Output signal repeatability, % FS	±0,05
3.5 Long-term stability of the output signal range within 12 months, %	
3.5.1 For TM 0,1... - TM 1...	±0,25
3.5.2 For TM 1,6... - TM 100...	±0,15
3.6 Output signal error caused by the influence of overload pressure, % FS	
for zero output signal	±0,2
for output signal range	±0,05
3.7 Additional ambient temperature error, % FS/1°C	
3.7.1 For zero output signal	±0,05
3.7.2 For output signal range	
operating temperature range from -45 to +125 °C	±0,05
operating temperature range from +125 to +200 °C	-0,05±0,025
3.8 Additional vibration error of the output signal, % FS	±0,05

4 Electrical characteristics

4.1 Output signal at room temperature by stabilized DC voltage 10 V	
4.1.1 Zero output signal, mV	±10
4.1.2 Output signal range (FS), mV	150±50
for TM 0,1 ...; TM 0,16...; TM 0,25...	100±35
4.2 Strain gauge bridge resistance at room temperature, kOhm	3,40-4,85
4.3 Temperature resistance coefficient of the strain gauge bridge, K ⁻¹	(1,75±0,1)·10 ⁻³
4.4 Insulation resistance, MOhm	
at room temperature	100
at the upper ambient temperature value	20
4.5 Electrical insulation strength (AC voltage), V	700
4.6 Power supply by stabilized DC voltage, V	1-10

Microtensor

Pressure sensors TM Series

5 Mechanical characteristics

5.1 Vibration resistance (sinusoidal vibration):

Frequency range, Hzfrom 10 to 5000
Acceleration amplitude, m/s^2 500

5.2 Shock resistance (multiple mechanical shocks):

Shock acceleration peak, m/s^2 1000
Shock pulse width, ms2

5.3 Torque effect while installation, N·m

5.3.1 For TM 0,1... - TM 10... 30-35
5.3.2 For TM 16... - TM 100...50-60

6 Operating conditions

6.1 IP levelIP40

6.2 Sensor body (pressure connection) and membrane are made
of titanium alloy with 87 % of titanium.

6.3 Pressure media - gases, liquids and their mixtures
not aggressive to the titanium alloy (air, sea water,
5 % vitriol acid , chlorine water, chloride solutions,
oils, ethyne etc)

Microtensor

Pressure sensors TM Series

7 Overall and mounting dimensions

7.1 Version with pins

TM 0,1(0,16)-...-P

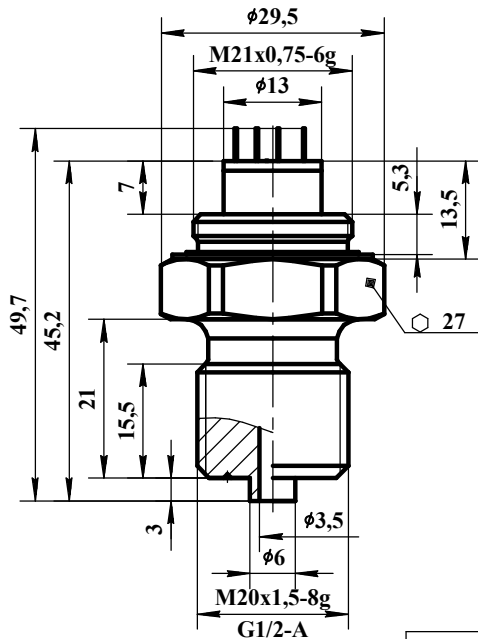

Drawing 1

Thread	Code
M20x1,5-8g	M
G1/2-A	G

TM 0,25(0,4...1)-...-P

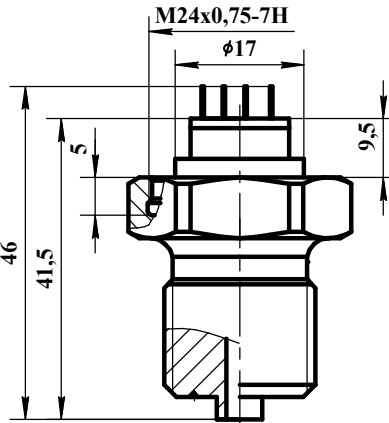

The rest -
ref. drawing 1

Drawing 2

TM 1,6(2,5...100)-...-P

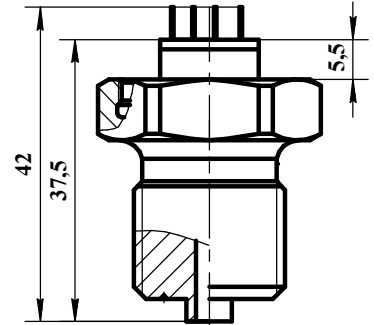

The rest -
ref. drawings 1 and 2

Drawing 3

7.2 Version with wires

TM 0,1(0,16)-...-L

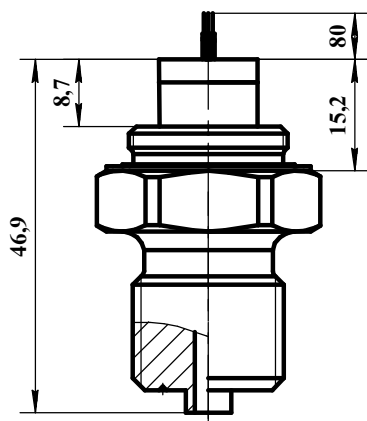

The rest -
ref. drawing 1

Drawing 4

TM 0,25(0,4...1)-...-L

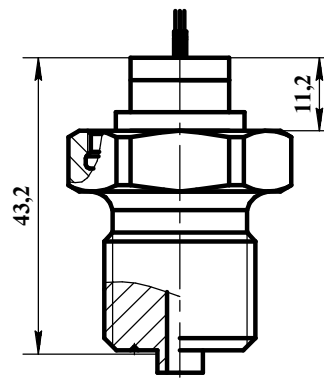

The rest -
ref. drawings 1, 2 and 4

Drawing 5

TM 1,6(2,5...100)-...-L

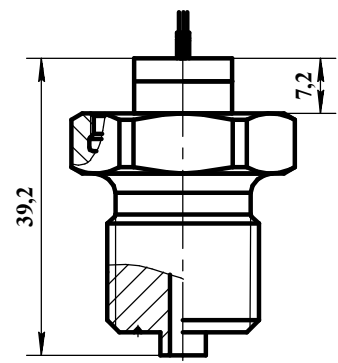

The rest -
ref. drawings 1, 2 and 4

Drawing 6

Microtensor

Pressure sensors TM Series

8 Circuit diagram

"Closed bridge" diagram

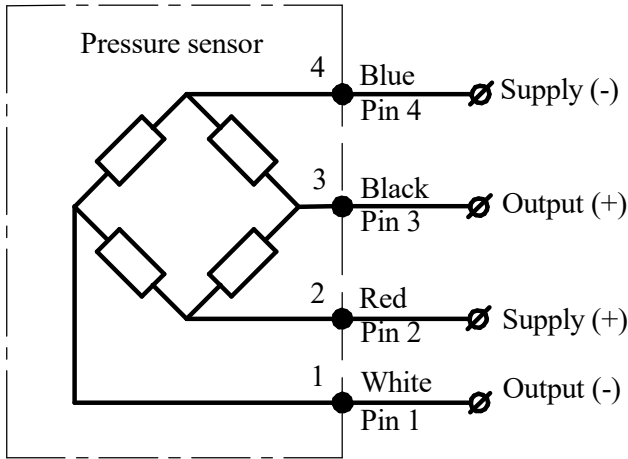

"Open bridge" diagram

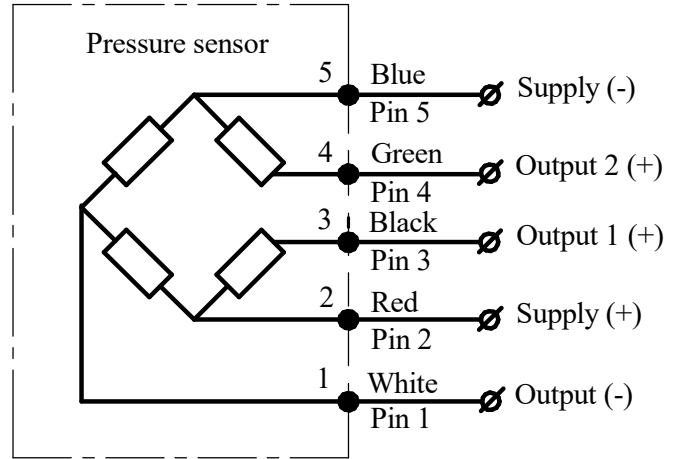

Pins configuration

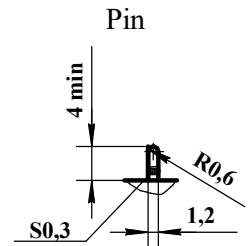
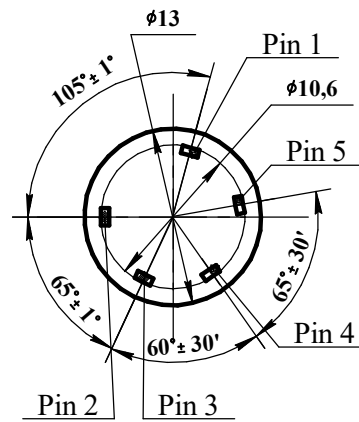
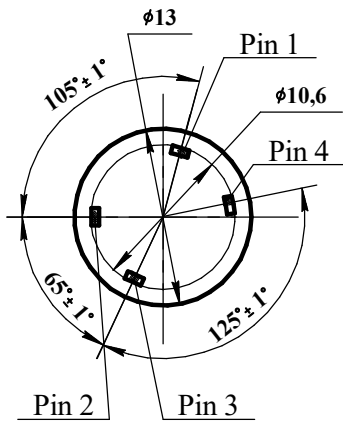

9 Mounting diagram

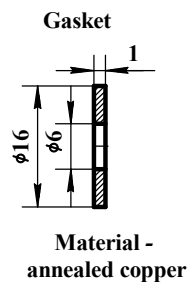
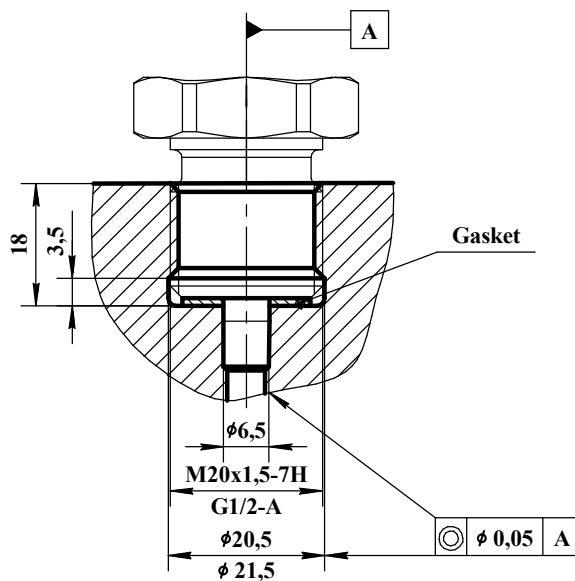

Microtensor

Pressure sensors TM Series

10 Type designation

	TM	XXX	XX	X	X
Series					
Upper gauge pressure limit					
0,1; 0,16; 0,25; 0,4; 0,6; 1; 1,6; 2,5; 4; 6; 10; 16; 25; 40; 60; 100 MPa					
Operating ambient temperature range					
Version 1 - from - 45 to + 125 °C; Version 2 - from - 45 to + 155 °C; Version 3 - from - 45 to + 200 °C					
Circuit					
0 - “closed bridge” circuit; 1 - “open bridge” circuit					
Thread code					
M - M20x1,5-8g; G - G1/2-A					
Electrical connection					
L - flexible wire 80 mm length; P - pin 4,5 mm height					

Order example of pressure sensor

Pressure sensor of TM series, intended for pressure conversion from 0 to 40 MPa, for operation within temperature range from - 45 to + 200 °C, with “closed bridge” circuit, M20x1,5-8g thread and flexible wire 80 mm length:

Pressure sensor TM 40-30-M-L.

Note: if wished, the wire length (standard 80 mm) can be changed, in this case the required length should be added to the wire code L, for example:

Pressure sensor TM 40-30-M-L100.

11 Marking

Marking on the sensor body must contain following information: series, upper gauge pressure limit in MPa, version of the operating temperature range, circuit type, thread code and order number

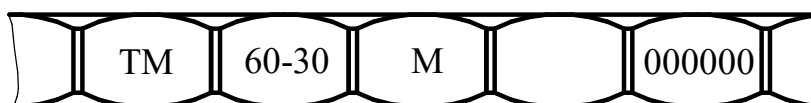

Microtensor

Pressure sensors TM Series