



## Microelectronic gauge pressure sensors PT Series

- ▶ Resolution 0,01 %
- ▶ Operating pressure range  
from 0-4 to 0-150 MPa
- ▶ Operating temperature range  
from -45 to +200 °C
- ▶ Electrical insulation  
strength – 700 V
- ▶ Titanium body



### Applications

- Industrial automatics
- Oil and gas industry
- Hydraulics/Pneumatic
- Pumping stations/ Compressors
- Heat metering

- The sensors are intended for proportional conversion of pressure into electric signal.

### New solutions in pressure measurement – “Silicon-on-Sapphire” Technology

- ✓ Sensitive element of pressure sensors is a two-layer sapphire-titanium diaphragm with monocrystal silicon resistance strain gauges.
- ✓ Monocrystal sapphire diaphragm is a perfect elastic element that due to connection with titanium acquires the best quality as to the deformation level, and preserves its elastic properties up to +400°C.
- ✓ Monocrystal silicon resistance strain gauges are automatically connected with sapphire (heteroepitaxy method) and provide almost no hysteresis or fatigue effects.
- ✓ Exceptional insulating properties and radiation resistance of sapphire enable to use the sensitive element within temperature range from -200 to +350°C under the effect of high electromagnetic interferences and radiation.
- ✓ Strain gauges elements are manufactured in groups by solid-state micro-electronic methods and provide high quality and good repeatability of the output parameters.

*Microtensor*

Pressure sensors PT Series

# Datasheet

## 1 Nominal, overload and burst pressure

Designation	Nominal pressure, MPa	Overload pressure, MPa	Burst pressure, MPa
PT 4...	0...4	-0,1...8	12
PT 6...	0...6	-0,1...12	18
PT 10...	0...10	-0,1...20	30
PT 16...	0...16	-0,1...32	48
PT 25...	0...25	-0,1...50	75
PT 40...	0...40	-0,1...80	120
PT 60...	0...60	-0,1...120	180
PT 100...	0...100	-0,1...150	250
PT 150...	0..150	-0,1...165	300

## 2 Temperature ranges

### 2.1 Operating temperature range

2.1.1 Version 1 ..... from - 45 to + 125°C

2.1.2 Version 2 ..... from - 45 to + 155°C

2.1.3 Version 3 ..... from - 45 to + 200°C

### 2.2 Limiting temperature range

2.2.1 Version 1 ..... from - 60 to + 130°C

2.2.2 Version 2 ..... from - 60 to + 160°C

2.2.3 Version 3 ..... from - 60 to + 205°C

*Microtensor*

Pressure sensors PT Series

### 3 Accuracy parameters

3.1 Resolution, % FS	0,01
3.2 Non-linearity, % FS	±0,15
3.3 Hysteresis, % FS	0,05
3.4 Output signal repeatability, % FS	±0,05
3.5 Long-term stability of the output signal range within 12 months, %	±0,15
3.6 Output signal error caused by the influence of overload pressure, % FS	
for zero output signal	±0,2
for output signal range	±0,05
3.7 Additional ambient temperature error, % FS/1°C	
3.7.1 For zero output signal	±0,05
3.7.2 For output signal range	
operating temperature range from -45 to +125 °C	±0,05
operating temperature range from +125 to +200 °C	-0,05±0,025
3.8 Additional vibration error of the output signal, % FS	±0,05

### 4 Electrical characteristics

4.1 Output signal at room temperature, mV	
4.1.1 Zero output signal	±15
4.1.2 Output signal range (FS)	150±50
4.2 Strain gauge bridge resistance at room temperature, kOhm	3,40-4,85
4.3 Temperature resistance coefficient of the strain gauge bridge, K <sup>-1</sup>	(1,70±0,15)·10 <sup>-3</sup>
4.4 Insulation resistance, MOhm	
at room temperature	100
at the upper ambient temperature value	20
4.5 Electrical insulation strength (AC voltage), V	700
4.6 Power supply - stabilized DC voltage, V	1-10
Output signal is rated by the voltage 10 V.	

### 5 Mechanical characteristics

5.1 Vibration resistance (sinusoidal vibration):	
Frequency range, Hz	from 10 to 5000
Acceleration amplitude, m/s <sup>2</sup>	500
5.2 Shock resistance (multiple mechanical shocks):	
Shock acceleration peak, m/s <sup>2</sup>	1000
Shock pulse width, ms	2-5
5.3 Torque effect while installation should not be higher than, N·m	30

*Microtensor*

Pressure sensors PT Series

## 6 Operating conditions

- 6.1 IP level ..... IP40
- 6.2 Sensor body (pressure connection) and membrane are made of titanium alloy with 87 % of titanium.
- 6.3 Pressure media - gases, liquids and their mixtures not aggressive to the titanium alloy (air, sea water, 5 % vitriol acid , chlorine water, chloride solutions, oils, ethyne etc)

## 7 Overall and mounting dimensions

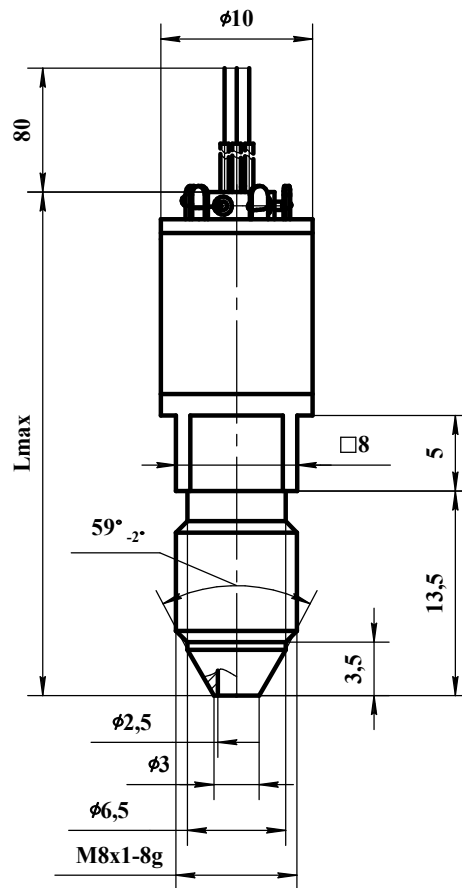

Designation	L max, mm
PT 4-... - PT 25...	36
PT 40... - PT 150...	34

*Microtensor*

Pressure sensors PT Series

## 8 Circuit diagram

Electrical connection - flexible wire with section 0,08 or 0,12 mm<sup>2</sup> in teflon insulation

"Closed bridge" diagram

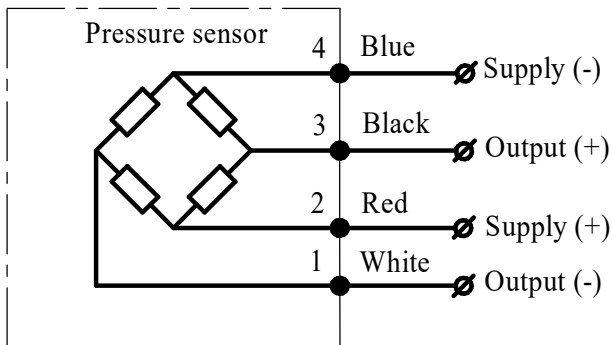

"Open bridge" diagram

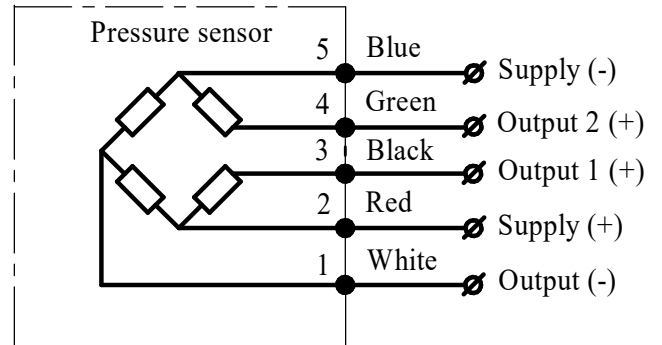

## 9 Mounting diagram

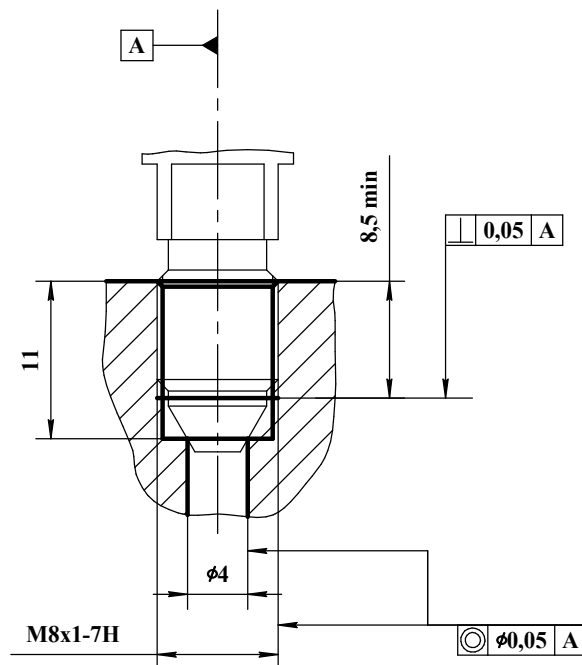

*Microtensor*

Pressure sensors PT Series

## 10 Type designation

	PT	XXX - XX
Series		
Upper gauge pressure limit		
4; 6; 10; 16; 25; 40; 60; 100; 150 MPa		
Operating ambient temperature range		
Version 1 - from - 45 to + 125 °C; Version 2 - from - 45 to + 155 °C; Version 3 - from - 45 to + 200 °C		
Curcuit		
0 - “closed bridge” circuit; 1 - “open brigde” circuit		

### Order example of pressure sensor

Pressure sensor of PT series, intended for pressure conversion from 0 to 100 MPa, for operation within temperature range from - 45 to + 125 °C, with “open bridge” circuit:

Pressure sensor PT 100-11.

Note: if wished, the wire length (standard 80 mm) can be changed, in this case the required length should be added to the wire code L, for example:

Pressure sensor PT 100-11-L150.

## 11 Marking

Marking on the sensor body must contain following information: designation of the sensor and order number



*Microtensor*

Pressure sensors PT Series